

Technical specifications: **DKV Series**



Vane-rotary compressors
 -High efficiency
 -Light and compact
 -Low noise and vibration



www.valeocompressors.com

MODEL	DKV06R	DKV08R	DKV10R
DISPLACEMENT	60cm ³ /rev.	80cm ³ /rev.	105cm ³ /rev.
NUMBER OF CYLINDERS	5	5	5
RANGE	800-7000	800-7000	800-7000
REFRIGERANT	HFC-134a	HFC-134a	HFC-134a
OIL	ZXL 200PG	ZXL 200PG	ZXL 200PG
WEIGHT	3.4kg (with clutch)	4.0kg (with clutch)	4.0kg (with clutch)
MOUNT	Direct	Direct	Direct

PERFORMANCE CURVES: DKV Series

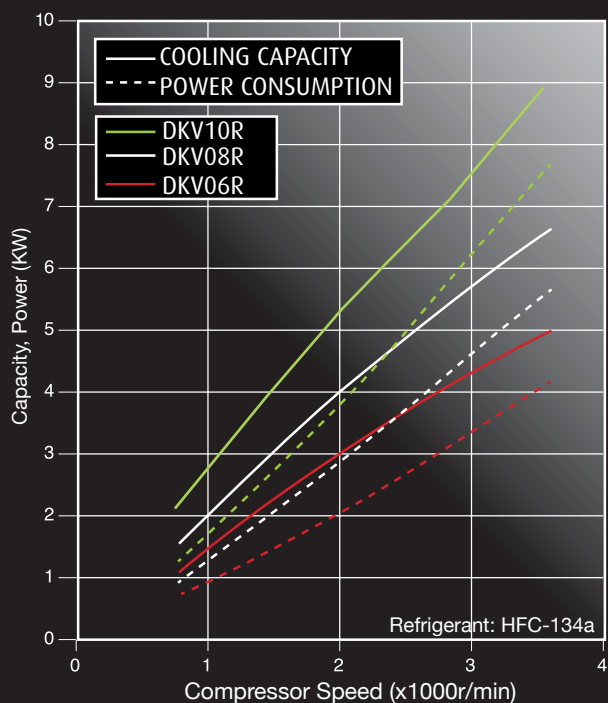

TEST CONDITIONS
 Discharge pressure: 1.52MPa (gage)
 Suction pressure : 0.18MPa (gage)
 Sub cool :5°C Super heat : 10°C

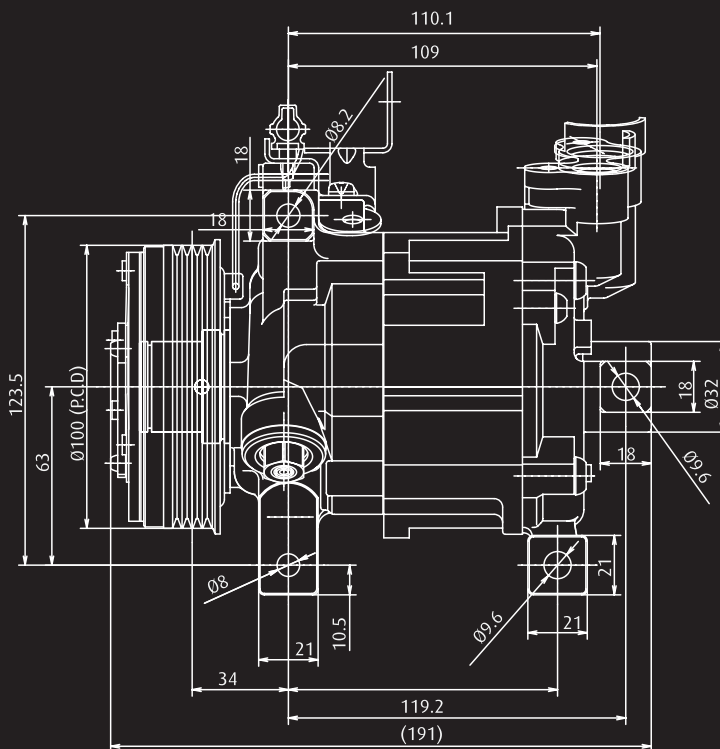

DKV-10R Design

