

# Compressor for Bus Air Conditioning

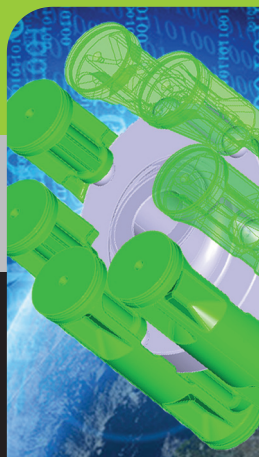

## TM-55 & TM-65 Compressors The large displacement compressor by Valeo

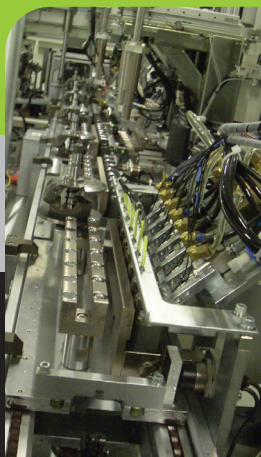

valeo added 

Copyright © 2010 Valeo Compressors. All rights reserved.

**Valeo**  
Automotive technology, naturally

# Innovative solution for Bus Air Conditioning

The new Valeo **TM-55 & TM-65** compressors are the achievement of Valeo Compressors after fifty of years cutting-edge innovations and customer oriented product development. Customers have praised Valeo Compressors know-how, technologies and heavy duty products which ideally suit bus applications.

Our expertise and engineering excellence are featured today in the new Valeo **TM-55 & TM-65**, which are released after a long and demanding validation program in our heavy duty R&D center in Japan. The full qualification of this new product was issued after extensive and successful runs on current bus air conditioning system equipments under the hottest climates in Asia and in the Middle East.

The operational excellence of Valeo **TM-55 & TM-65** compressors is guaranteed today for large buses and coaches air conditioning systems.

The high cooling capacity of Valeo **TM-55 & TM-65** is provided along with a compact size and a light weight.

Running smoothly and quietly, their reliability combined with their excellent efficiency contributes to reduce significantly operating costs for companies running buses equipped with Valeo **TM-55 & TM-65** air conditioning compressors.

The benefits of Valeo **TM-55 & TM-65** make it the best solution for large bus air conditioning systems.

MODEL	TM-55	TM-65
TECHNOLOGY	Heavy Duty Swash Plate	
DISPLACEMENT	550 cc / 33.56 in <sup>3</sup>	635 cc / 38.75 in <sup>3</sup>
NUMBER OF CYLINDERS	14 (7 double-headed pistons)	
REVOLUTION RANGE	600-4000 rpm	
DIRECTION OF ROTATION	Clockwise (viewed from clutch)	
BORE	38.5 mm (1.52 in)	
STROKE	33.7 mm (1.30 in)	38.9 mm (1.53 in)
LUBRICATION SYSTEM	Lubrication by oil pump	
REFRIGERANT	HFC-134a	
OIL (QUANTITY)	ZXL 100PG PAG OIL (1500cc / 0.40 gal) (or POE Option)	
WEIGHT	18.1kg / 39.9lb (w/o Clutch)	
DIMENSIONS Length - Width - Height	341 - 194 - 294 (mm) 13.4 - 7.64 - 9.33 (in)	
MOUNTING	Direct (side or base)	

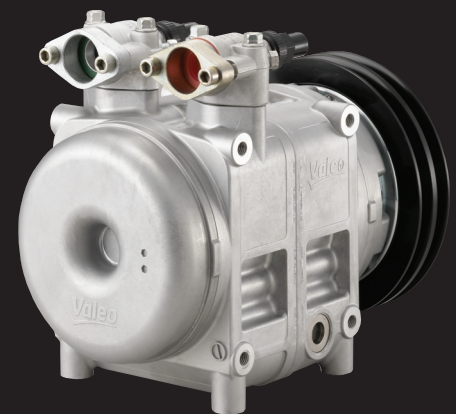

# Valeo **TM-55 & TM-65** benefits

## Valeo **TM-55 & TM-65** Benefits for Bus and Coach Operators

Best Efficiency :	<ul style="list-style-type: none"><li>-High cooling with lower fuel consumption</li><li>-Save costs with <b>TM-55 &amp; TM-65</b> equipped Buses</li></ul>
Reliability & Durability :	<ul style="list-style-type: none"><li>-“Made in Japan” manufacturing quality standards</li><li>-Lip type shaft seal design ensuring oil leakage free operation</li><li>-Balanced design reducing noise and vibrations</li><li>-Improved durability ensures long-term cost savings</li></ul>
High Cooling Capacity :	<ul style="list-style-type: none"><li>-Best cooling capacity at idling (traffic jam, stops,...)</li><li>-Guarantees Passengers’ comfort</li></ul>

## Valeo **TM-55 & TM-65** Benefits for Bus Makers

Lightweight & compact :	<ul style="list-style-type: none"><li>-Easy to mount &amp; to maintain (oil sight glass, no leakage)</li><li>-Improved field serviceability</li><li>-Most challenging integration made easier by design</li></ul>
Balanced 14 Cylinders design :	<ul style="list-style-type: none"><li>-Decreased constraints on each valve and pistons</li><li>-Less stress, improved durability</li><li>-Robust design and high precision manufacturing</li><li>-Better reliability with less parts (up to -40% vs. competitors)</li></ul>
Performance-Cost Mix :	<ul style="list-style-type: none"><li>-Highly Competitive pricing for better performances</li></ul>

## Valeo **TM-55 & TM-65** Benefits for A/C Systems Makers

Perfect Compatibility :	<ul style="list-style-type: none"><li>-Great adaptability to any chassis, engines</li><li>-Natural integration to any A/C systems</li></ul>
Premium Quality product :	<ul style="list-style-type: none"><li>-Valeo design ensuring performance &amp; durability</li><li>-Japan design and manufacturing guaranteed origin</li></ul>
Valeo warranty and Competitive pricing :	<ul style="list-style-type: none"><li>-0 defect production quality &amp; skilled experienced staff</li><li>-Warranty in line with customers standards</li><li>-Moderate pricing for innovation and quality</li></ul>

# Valeo TM-55 & TM-65 Compressors

Oil fill-up plug for better inner oil return

Lip type shaft seal providing ultimate reliability & performance

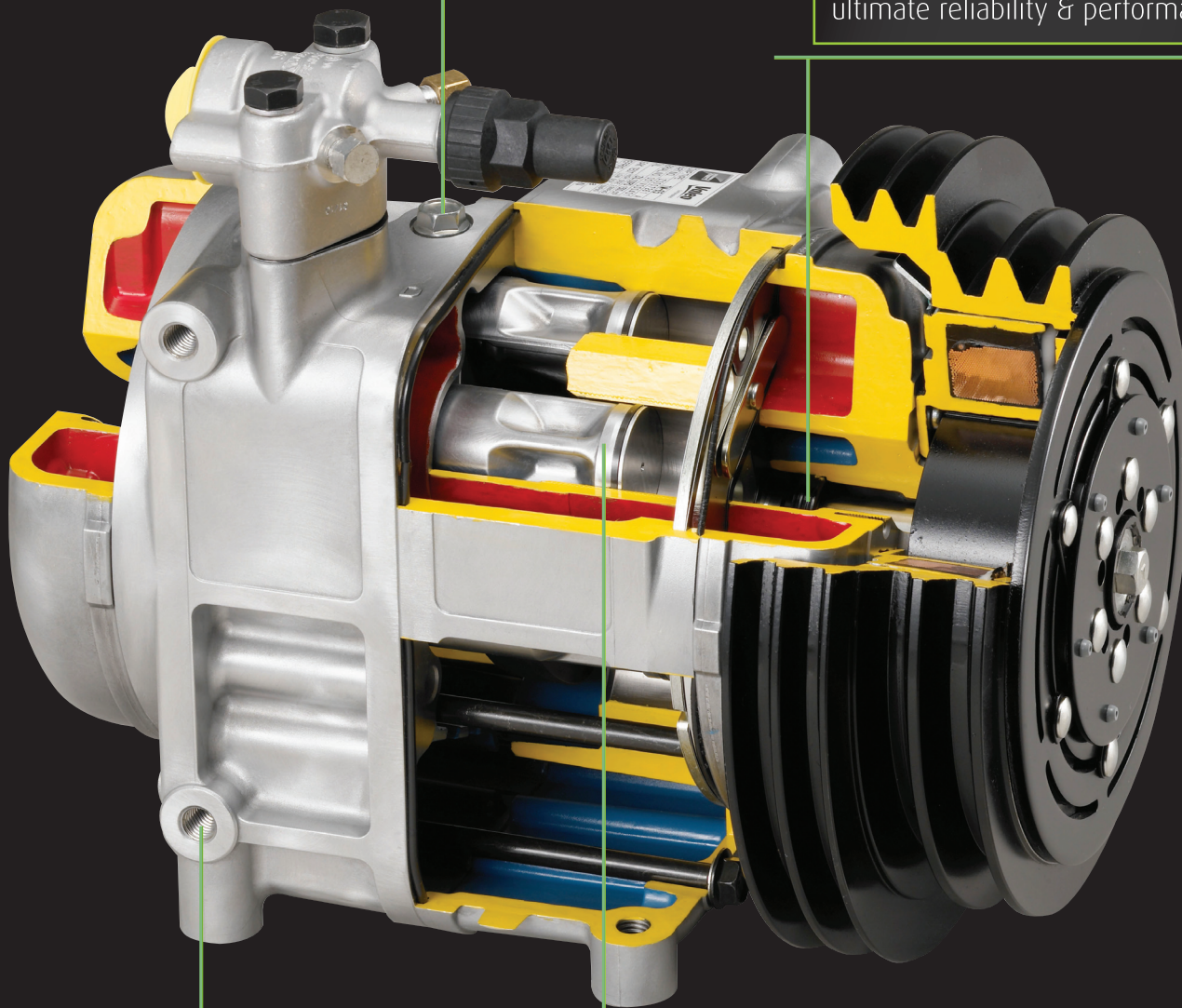

Compact & robust design enabling easy mounting configurations

7 double-headed pistons architecture ensuring smooth and quiet operations

Light & Compact, Ultimate Reliability, Highest Performance

**valeo** added 

# Valeo TM-55 & TM-65 performance

## Valeo TM-55 & TM-65 Performance data (R134a)

Compressor model	Conditions		Cooling capacity $Q_0$ (Watt)						Power consumption $P_W$ (kWatt)					
			Evap temp ( $^{\circ}\text{C}$ )						Evap temp ( $^{\circ}\text{C}$ )					
	Cond. temp ( $^{\circ}\text{C}$ )	$\frac{P_s \text{ (MPa)}}{P_d \text{ (MPa)}}$	10	7.5	5	0	-5	-10	10	7.5	5	0	-5	-10
<b>TM-55</b>	40	0.91	38,077	33,734	29,352	23,921	19,864	15,139	6.55	6.37	6.13	5.86	5.40	4.82
	50	1.21	33,057	29,293	25,481	21,135	17,397	12,992	7.49	7.17	6.81	6.33	5.84	5.12
	60	1.58	28,314	25,027	21,655	17,620	14,425	10,554	8.24	7.84	7.42	6.79	6.19	5.31
<b>TM-65</b>	40	0.91	42,880	37,190	34,060	28,190	22,510	17,300	7.70	7.48	7.29	7.08	6.50	5.80
	50	1.21	35,730	31,970	29,230	23,590	18,650	14,700	8.82	8.46	8.28	7.60	6.81	6.05
	60	1.58	30,650	27,800	24,870	19,860	15,500	11,970	9.78	9.42	8.94	8.02	7.01	6.07

Compressor speed=1450 RPM , suction gas temperature=20 $^{\circ}\text{C}$

## Valeo TM-55 & TM-65 Conversion factors

Power data at different rotation speed can be approximated with conversion factors below

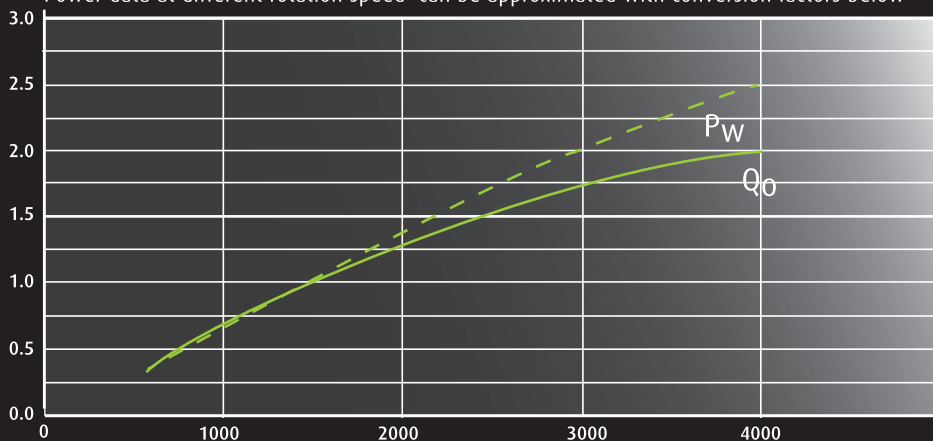

## Valeo TM-55 & TM-65 Application limits

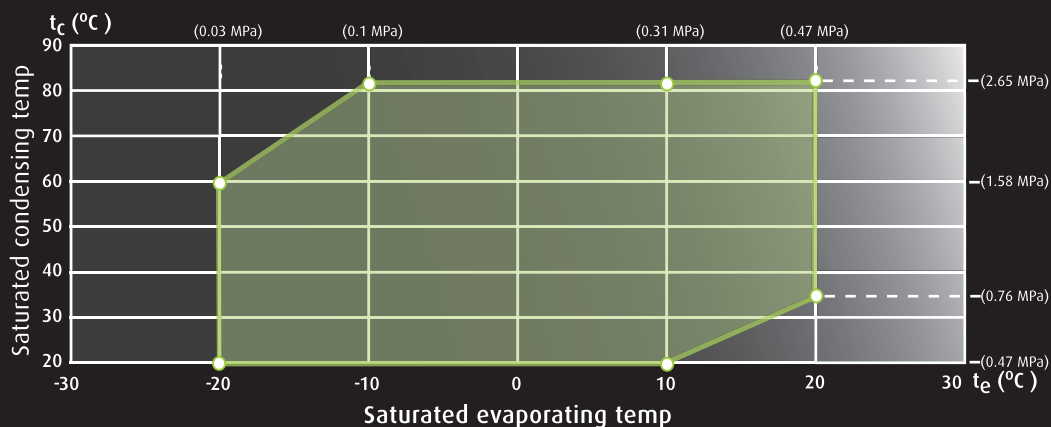

$t_c$  : Condensing temperature ( $^{\circ}\text{C}$ )

$t_e$  : Evaporating gas temperature ( $^{\circ}\text{C}$ )

# Valeo TM-55 & TM-65 dimensions

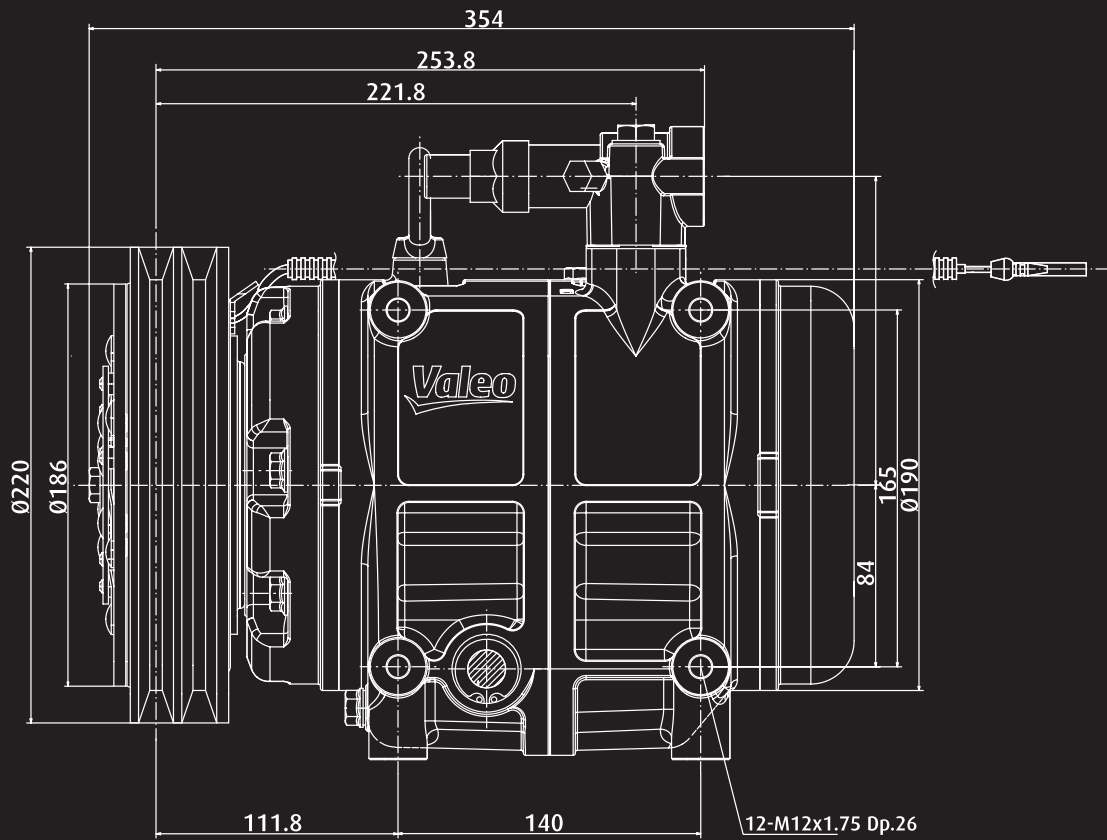
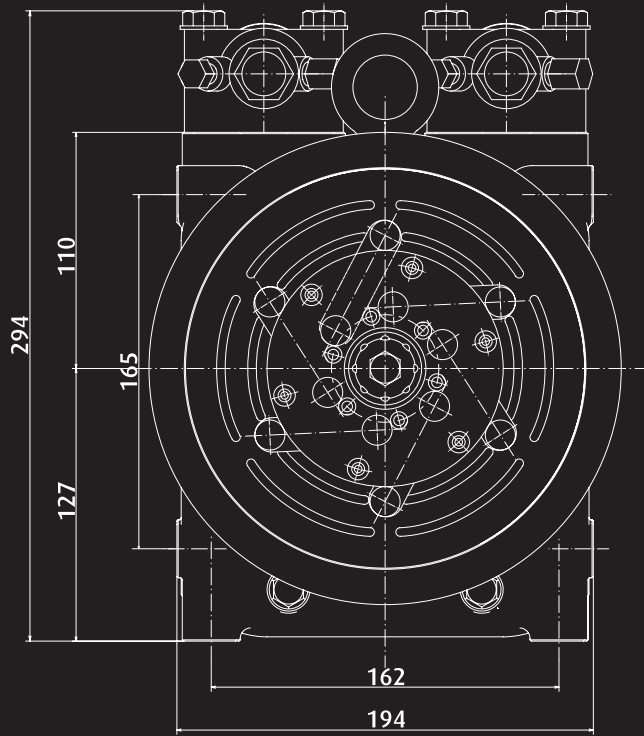

# TM-55 & TM-65 Magnetic Clutch

VALEO **TM-55 & TM-65** are available either as a compressor and magnetic clutch assembly or as a compressor body that customers can fit with compatible magnetic clutches. The magnetic clutch design Valeo has been promoting for more than 20 years is now gradually adopted as well by other major market actors.

Our compressors and magnetic clutches have successfully passed the thousand hours of long validation tests in Valeo Compressors research center laboratory. Operational excellence was demonstrated during hot season testing on field under challenging climates in the most stressful conditions.

Being able to rely on our robust magnetic clutch provides the best way to reduce fuel consumption without using additional unloading devices that decrease significantly the efficiency and durability of the compressor. The range of Valeo magnetic clutches ensures an unmatched reliability and the longest durability that perfectly matches the Valeo **TM-55 & TM-65** compressor qualities.

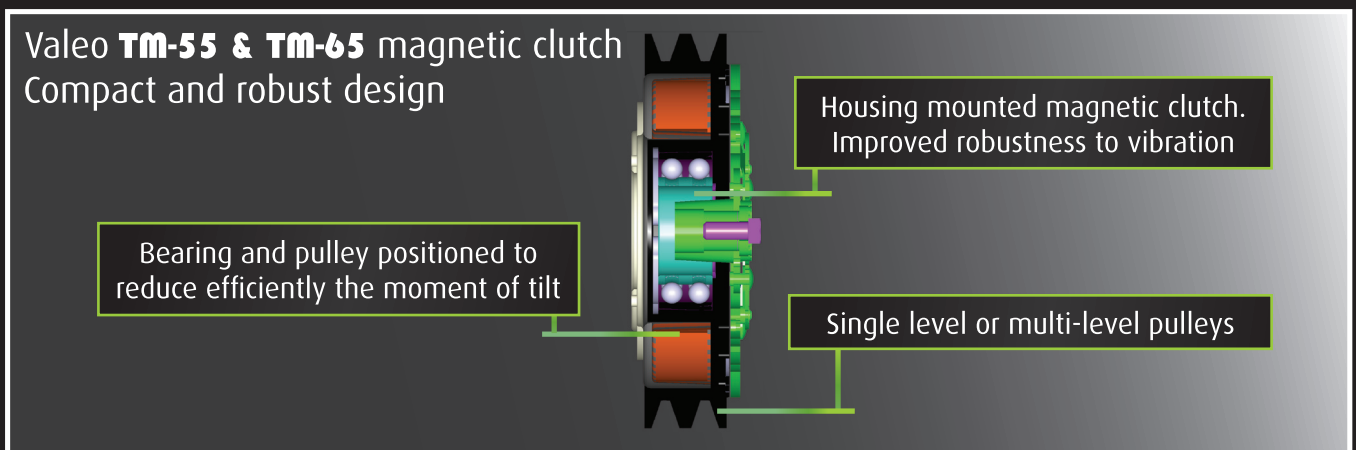

## Valeo **TM-55 & TM-65** standard range of magnetic clutches:

**BW220 AW260**

4 grooves

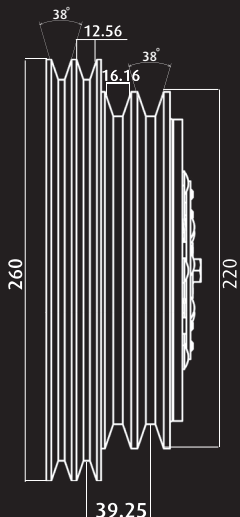

**BW220 AW250**

4 grooves

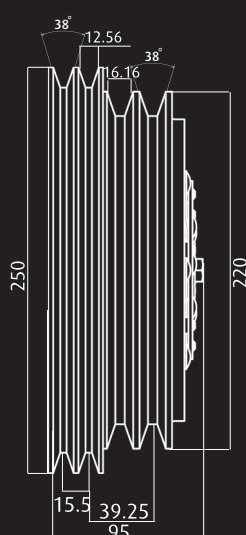

**BW220**

2 grooves



**PK196**

8 grooves

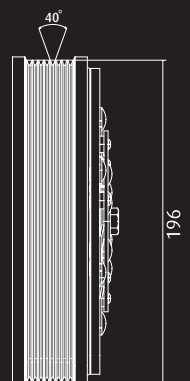

# New Valeo **TM-55** & **TM-65** Compressors for Bus Air-Conditioning

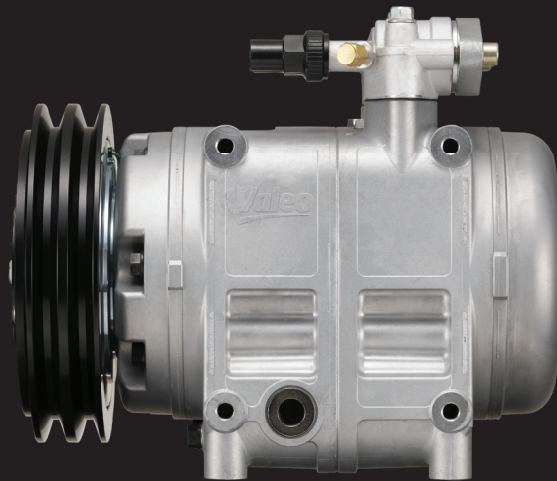

## Valeo **TM-55** & **TM-65** Benefits

- High reliability
- Integration flexibility
- Great cooling capacity
- Enhanced performance
- Lower fuel consumption
- Compact & robust design
- Improved field serviceability
- Reduced noise and vibrations
- Staggering value through innovation

valeo added 

[www.valeocompressors.com](http://www.valeocompressors.com)

EA28E-13010

### Asia

39 Sendai, Kumagaya-shi  
Saitama-ken 360-0193 Japan  
Phone: +81 (0) 48 539 3800  
Fax: +81 (0) 48 539 3843  
Email: [vc-oura-sales@valeo.com](mailto:vc-oura-sales@valeo.com)

### China

No.2677 Shiji Avenue, Eco. & Tec. Dvt  
Zone 130031 Changchun, Jilin PRC  
Phone: +86 (0) 431 8499 2025  
Fax: +86 (0) 431 8499 2004  
Email: [vc-changchun-sales@valeo.com](mailto:vc-changchun-sales@valeo.com)

### Europe & Middle East Africa

6, rue Francois Cevert  
BP71014 49015 Angers, France  
Phone: +33 (0) 241686 234  
Fax: +33 (0) 241 686 239  
Email: [vc-angers-sales@valeo.com](mailto:vc-angers-sales@valeo.com)

### Americas

2520 Esters Blvd #100  
Dallas, TX 75261 United States  
Phone: +1 972 456 1077  
Fax: +1 972 456 1090  
Email: [vc-dallas-sales@valeo.com](mailto:vc-dallas-sales@valeo.com)