

Technical specifications: DCS Series



variable displacement swash plate compressors

- Good drivability
- High speed operation
- Low power consumption



www.valeocompressors.com

MODEL	DCS-14 IC	DCS-17 IC	DCS-17 E	DCS-17 EC
DISPLACEMENT	140cm ³ (maximum)	171cm ³ (maximum)	171cm ³ (maximum)	171cm ³ (maximum)
NUMBER OF CYLINDERS	6	7	7	7
RANGE	700 - 7000	700 - 7000	700 - 7000	700 - 7000
REFRIGERANT	HFC -134a	HFC -134a	HFC -134a	HFC -134a
OIL	ZXL 100PG (PAG OIL) 150cm ³	ZXL 100PG (PAG OIL) 150cm ³	ZXL 100PG (PAG OIL) 150cm ³	ZXL 100PG (PAG OIL) 150cm ³
WEIGHT	6 Kg (with clutch)	6.6 Kg (with clutch)	4.9 Kg (with pulley)	6.6 Kg (with clutch)
MOUNT	Direct	Direct	Direct	Direct

PERFORMANCE CURVES: DCS Series

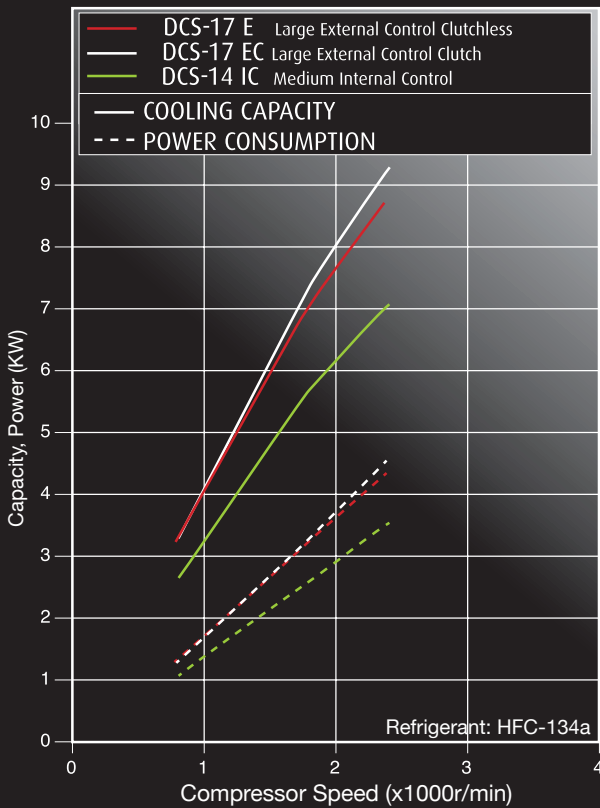

TEST CONDITIONS
 Discharge pressure: 1.52MPa (gage)
 Suction pressure : 0.18MPa (gage)
 Sub cool :5°C Super heat : 10°C

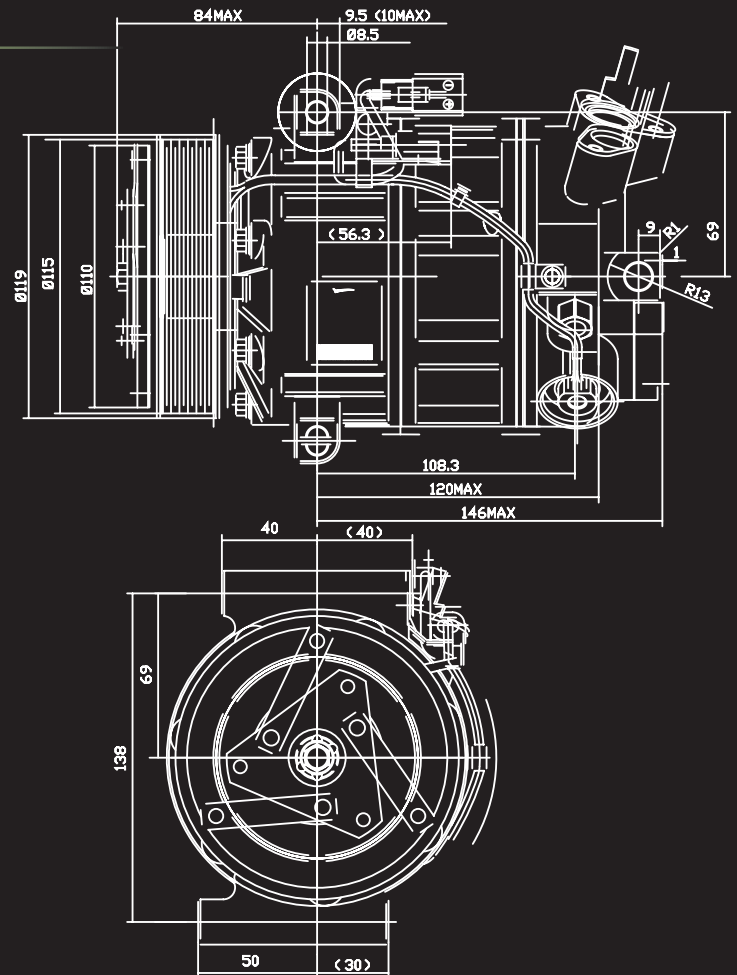

DCS17 External Control Design

