

# Technical specifications: TM13/ TM15/ TM16



Adaptable Heavy Duty compressors  
 -High reliability  
 -Especially suitable for truck and refrigeration applications  
 -Very wide product range



www.valeocompressors.com

MODEL	TM-13	TM-15*	TM-16
DISPLACEMENT	131cm <sup>3</sup> /rev.	147cm <sup>3</sup> /rev.	163cm <sup>3</sup> /rev.
NUMBER OF CYLINDERS	6	6	6
RANGE	700-6000	700-6000	700-6000
REFRIGERANT	HFC-134a	HFC-134a	HFC-134a
OIL	ZXL 100PG 150cm <sup>3</sup>	ZXL 100PG 150cm <sup>3</sup>	ZXL 100PG 180cm <sup>3</sup>
WEIGHT	6.3Kg (with clutch)	6.5Kg (with clutch)	7.1Kg (with clutch)
MOUNT	Ear or Direct	Ear or Direct	Ear or Direct

## PERFORMANCE CURVES: TM-13, TM15, TM-16

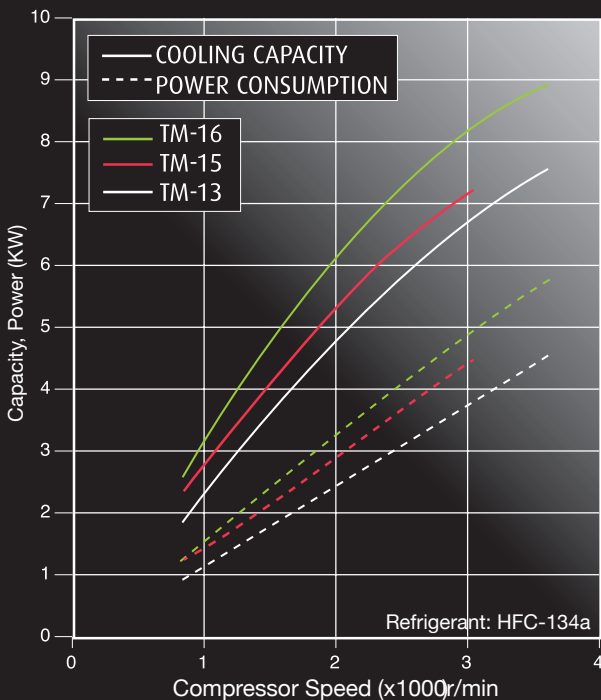

### TEST CONDITIONS

Discharge pressure: 1.52MPa (gage)  
 Suction pressure : 0.18MPa (gage)  
 Sub cool :5°C Super heat : 10°C

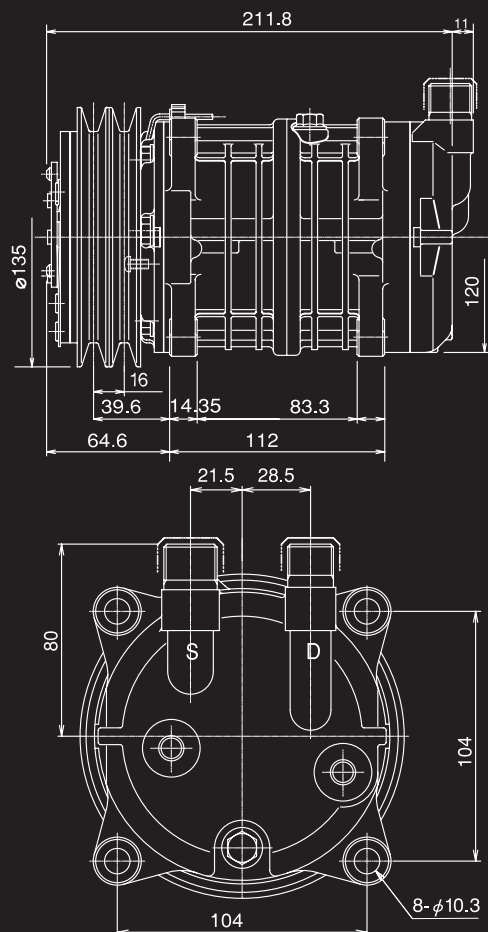

\*TM14 available on some markets is equivalent to TM15 (same fittings, size, options and performances)

## MAGNETIC CLUTCH VARIATIONS



135-1AG

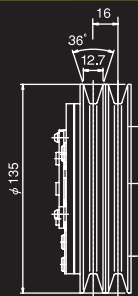

135-2AG



137-1BG

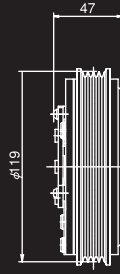

119-4PK

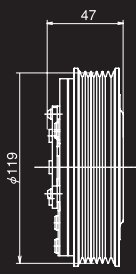

119-6PK

## CYLINDER HEAD VARIATIONS

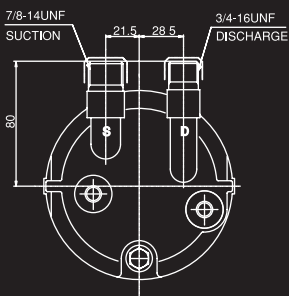

O-RING TYPE  
MOUNTING

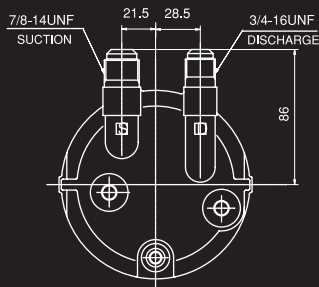

FLARE TYPE

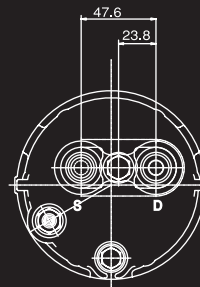

GM PAD TYPE

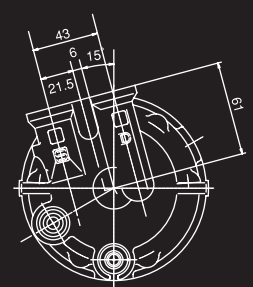

VERTICAL PAD TYPE

### EAR

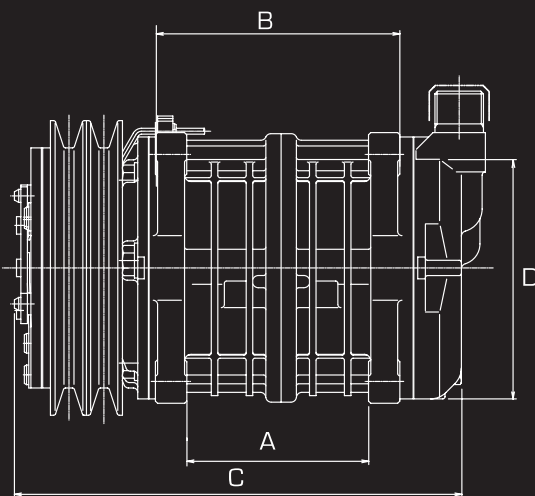

### DIRECT

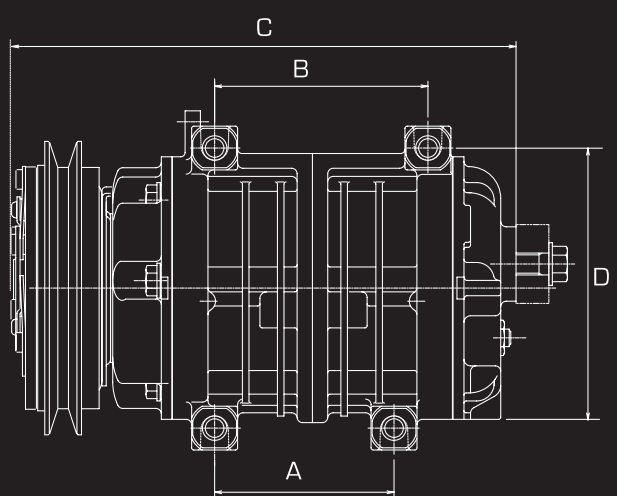

	A	B**	C	D	Oil capacity
<b>TM-13A</b>	83.3mm	112mm	223.3mm	104mm	150cc
<b>TM-13Ashort</b>	73.3mm	98mm	196.7mm	104mm	150cc
<b>TM-15A</b>	83.3mm	112mm	220.8mm	104mm	150cc
<b>TM-16A</b>	83.3mm	112mm	226.3mm	104mm	150cc

\*\* may vary with options

	A	B	C	D
<b>TM-13A (DM)</b>	82mm	82mm	223.3mm	138mm
<b>TM-15A (DM)</b>	78mm	90mm	228mm	128mm
<b>TM-16A (DM)S</b>	87mm	92mm	218mm	128mm